

TJA1029

ISO 17987/LIN 2.x/SAE J2602 transceiver with TXD dominant timeout

Rev. 3 — 18 December 2018

Product data sheet

1. General description

The TJA1029 is the interface between the Local Interconnect Network (LIN) master/slave protocol controller and the physical bus in a LIN network. It is primarily intended for in-vehicle subnetworks using baud rates up to 20 kBd and is compliant with LIN 2.0, LIN 2.1, LIN 2.2, LIN 2.2A, SAE J2602 and ISO 17987-4:2016 (12 V). The TJA1029 is pin-compatible with the TJA1020, TJA1021, TJA1022, TJA1027 and MC33662(B).

The protocol controller generates the transmit data stream. The TJA1029 converts the data stream into an optimized bus signal shaped to minimize ElectroMagnetic Emissions (EME). The LIN bus output pin is pulled HIGH via an internal termination resistor. For a master application, connect an external resistor in series with a diode between pin V_{BAT} and pin LIN. The receiver detects a receive data stream on the LIN bus input pin and transfers it via pin RXD to the microcontroller.

Power consumption is very low in Sleep mode. However, the TJA1029 can still be woken up via pins LIN and SLP_N. An integrated TXD dominant time-out function prevents the bus being driven to a permanent dominant state.

2. Features and benefits

2.1 General

- LIN 2.x/ISO 17987-4:2016 (12 V)/SAE J2602 compliant
- Baud rate up to 20 kBd
- Very low ElectroMagnetic Emissions (EME)
- Very low current consumption in Sleep mode with remote LIN wake-up
- Input levels compatible with 3.3 V and 5 V devices
- Integrated termination resistor for LIN slave applications
- Passive behavior in unpowered state
- Operational during cranking pulse: full operation from 5 V upwards
- Undervoltage detection
- K-line compatible
- Available in SO8 and HVSON8 packages
- Leadless HVSON8 package (3.0 mm × 3.0 mm) with low thermal resistance supporting Automated Optical Inspection (AOI) capability
- Dark green product (halogen free and Restriction of Hazardous Substances (RoHS) compliant)
- Pin-compatible subset of the TJA1020, TJA1021, TJA1022 and MC33662(B)
- Pin- and footprint-compatible with the TJA1027



2.2 Protection

- Very high ElectroMagnetic Immunity (EMI)
- Very high ESD robustness: ±8 kV according to IEC 61000-4-2 for pins LIN and V_{BAT}
- Bus terminal and battery pin protected against transients in the automotive environment (ISO 7637)
- Bus terminal short-circuit proof to battery and ground
- Thermally protected
- Initial TXD dominant check when switching to Normal mode
- TXD dominant time-out function

3. Quick reference data

Table 1. Quick reference data

| Symbol | Parameter | Conditions | Min | Typ | Max | Unit |
|------------------|---------------------------------|---|------|-----|------|------|
| V _{BAT} | battery supply voltage | limiting values | -0.3 | - | +42 | V |
| | | operating range | 5 | - | 18 | V |
| I _{BAT} | battery supply current | Sleep mode; V _{LIN} = V _{BAT} ; V _{SLP_N} = 0 V | 2.5 | 7 | 10 | μA |
| | | Standby mode; V _{LIN} = V _{BAT} ; V _{SLP_N} = 0 V | 2.5 | 7 | 10 | μA |
| | | Normal mode; V _{LIN} = V _{BAT} ; V _{SLP_N} = 5 V; V _{TXD} = 5 V | 200 | 800 | 1600 | μA |
| V _{LIN} | voltage on pin LIN | limiting value with respect to GND and V _{BAT} | -42 | - | +42 | V |
| V _{ESD} | electrostatic discharge voltage | on pin LIN; according to IEC 61000-4-2 | -8 | - | +8 | kV |
| T _{vj} | virtual junction temperature | limiting value | -40 | - | +150 | °C |

4. Ordering information

Table 2. Ordering information

| Type number | Package | | Version |
|-------------|---------|---|----------|
| | Name | Description | |
| TJA1029T | SO8 | plastic small outline package; 8 leads; body width 3.9 mm | SOT96-1 |
| TJA1029TK | HVSON8 | plastic thermal enhanced very thin small outline package; no leads; 8 terminals; body 3 × 3 × 0.85 mm | SOT782-1 |

5. Block diagram

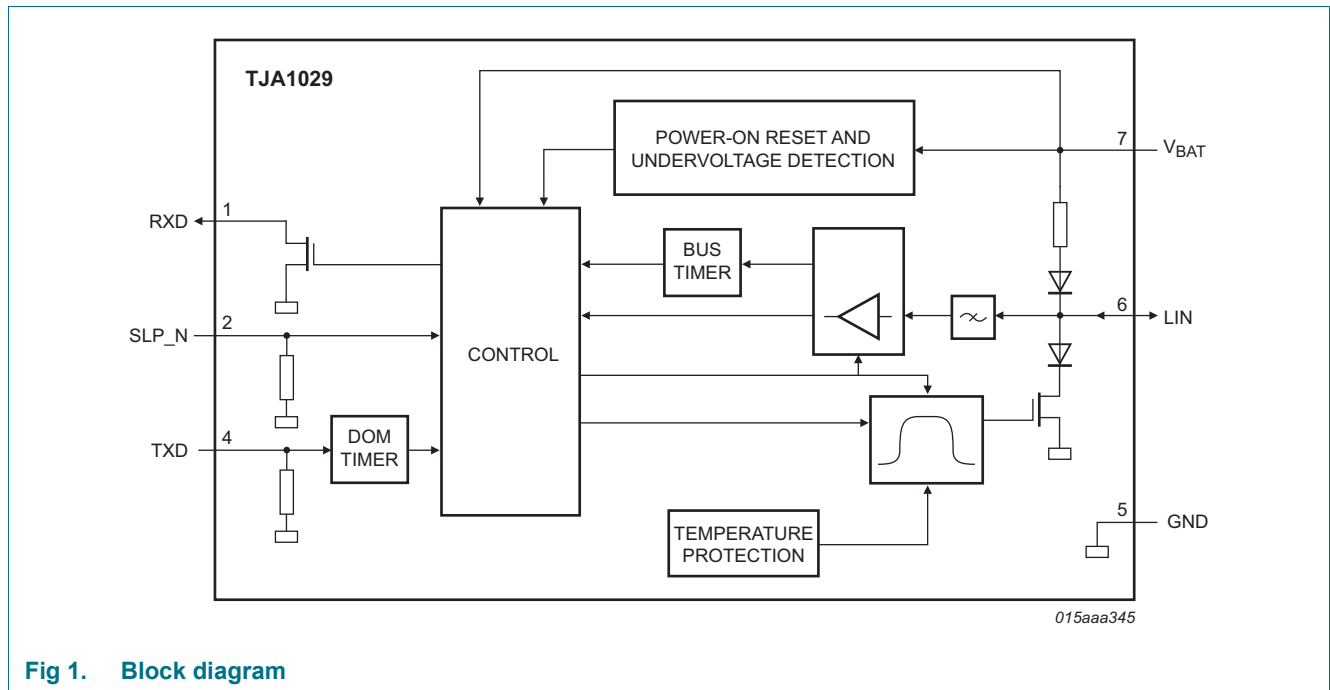
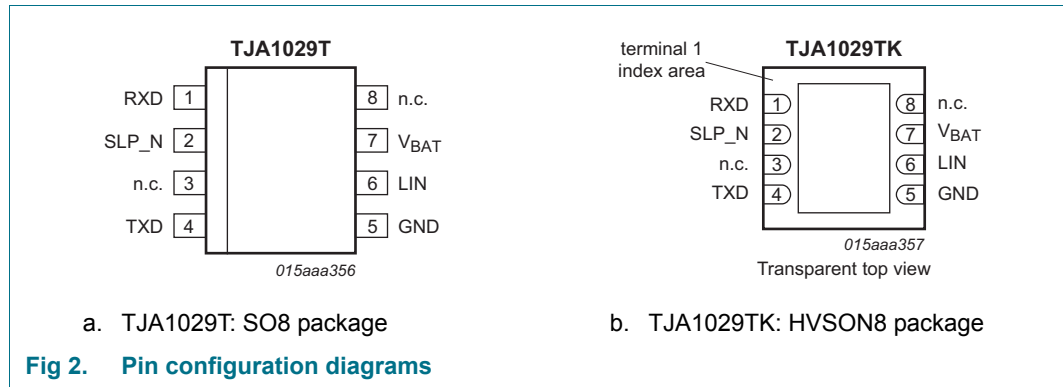

Fig 1. Block diagram

6. Pinning information

6.1 Pinning



6.2 Pin description

Table 3. Pin description

| Symbol | Pin | Description |
|------------------|------------------|--|
| RXD | 1 | receive data output (open-drain); active LOW after a wake-up event |
| SLP_N | 2 | sleep control input (active LOW); resets wake-up request on RXD |
| n.c. | 3 | not connected |
| TXD | 4 | transmit data input |
| GND | 5 ^[1] | ground |
| LIN | 6 | LIN bus line input/output |
| V _{BAT} | 7 | battery supply |
| n.c. | 8 | not connected |

[1] For enhanced thermal and electrical performance, solder the exposed center pad of the HVSON8 package to board ground.

7. Functional description

The TJA1029 is the interface between the LIN master/slave protocol controller and the physical bus in a LIN network. According to the Open System Interconnect (OSI) model, this interface makes up the LIN physical layer.

The LIN transceiver is optimized for, but not limited to, automotive applications with excellent ElectroMagnetic Compatibility (EMC) performance.

7.1 LIN 2.x/ISO 17987-4:2016 (12 V)/SAE J2602 compliant

The TJA1029 is fully LIN 2.0, LIN 2.1, LIN 2.2, LIN 2.2A, SAE J2602 and ISO 17987-4:2016 (12 V) compliant. The LIN physical layer is independent of higher OSI model layers (e.g. the LIN protocol). Consequently, nodes containing an ISO 17987-4:2016 (12 V) compliant physical layer can be combined, without restriction, with LIN physical layer nodes that comply with earlier revisions (LIN 1.0, LIN 1.1, LIN 1.2, LIN 1.3, LIN 2.0, LIN 2.1, LIN 2.2 and LIN 2.2A).

7.2 Operating modes

The TJA1029 supports modes for normal operation (Normal mode) and very-low-power operation (Sleep mode). An intermediate wake-up mode between Sleep and Normal modes is also supported (Standby mode). The state diagram is shown in [Figure 3](#).

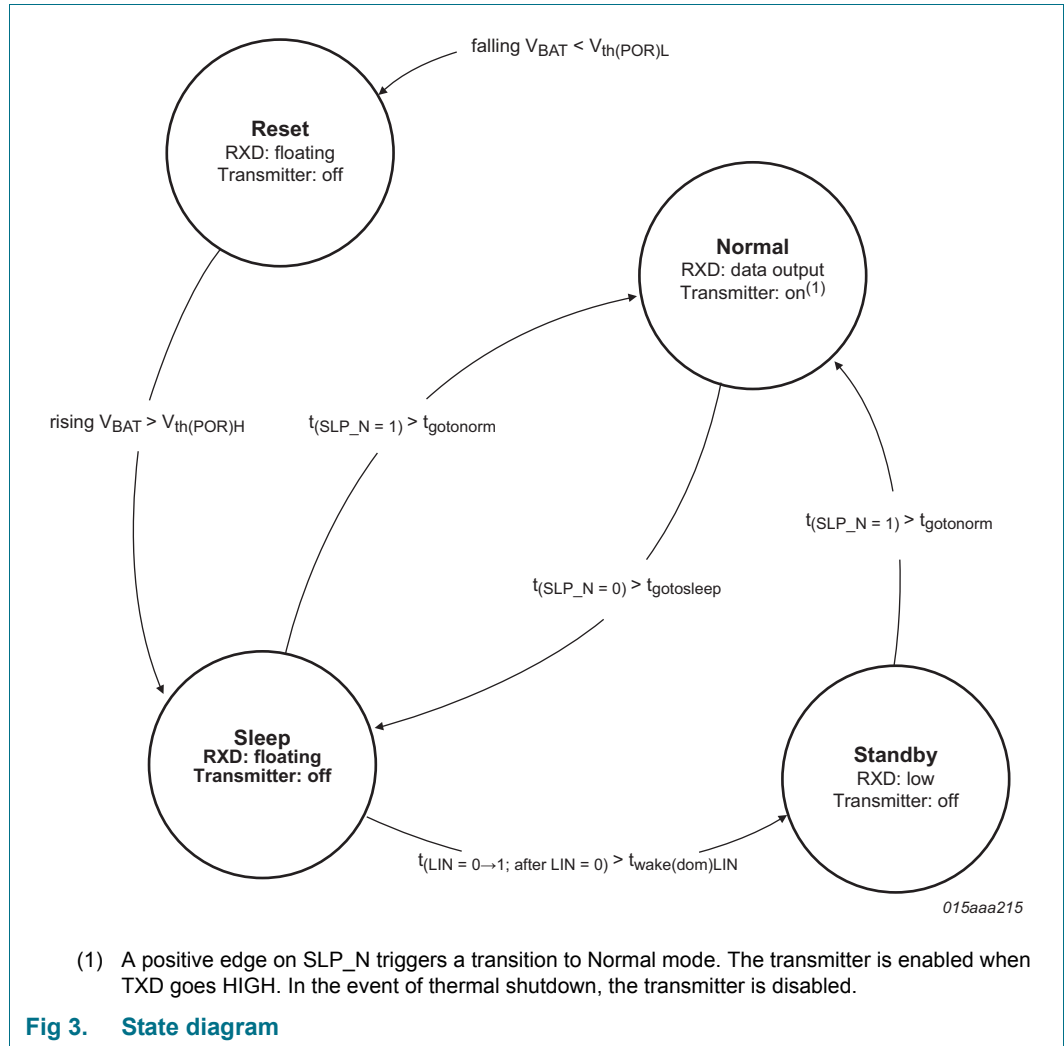

Fig 3. State diagram

Table 4. Operating modes

| Mode | SLP_N | RXD | Transmitter | Description |
|------------------------|-------|--|----------------------------|---|
| Reset | x | floating | off | all inputs ignored; all outputs drivers off |
| Sleep ^[1] | 0 | floating | off | no wake-up request detected |
| Standby ^[2] | 0 | LOW ^[3] | off | wake-up request detected |
| Normal | 1 | HIGH: recessive state LOW: dominant state | Normal mode ^[4] | bus signal shaping enabled |

- [1] The TJA1029 enters Sleep mode after a power-on reset (e.g. after switching on V_{BAT}).
- [2] The TJA1029 switches automatically to Standby mode when a LIN wake-up event occurs in Sleep mode.
- [3] The wake-up interrupt (on pin RXD) is released after a positive edge on pin SLP_N.
- [4] A positive edge on SLP_N triggers a transition to Normal mode. The transmitter will be off if TXD is LOW and will be enabled as soon as TXD goes HIGH.

7.2.1 Reset mode

When the TJA1029 is in Reset mode, it ignores all input signals and all output drivers are off. The TJA1029 switches to Reset mode when the voltage on V_{BAT} drops below the LOW-level power-on reset threshold, $V_{th(POR)L}$. When the voltage on V_{BAT} rises above the HIGH-level power-on reset threshold, $V_{th(POR)H}$, the TJA1029 switches to Sleep mode.

7.2.2 Sleep mode

The TJA1029 consumes significantly less power in Sleep mode than in Normal mode. Even though current consumption is extremely low in Sleep mode, the TJA1029 can still be woken up remotely via pin LIN or activated directly via pin SLP_N. Filters on the receiver input (LIN) and on pin SLP_N prevent unwanted wake-up events occurring due to automotive transients or radio frequency interference. All wake-up events must be maintained for a specific period ($t_{wake(dom)LIN}$ or $t_{gotonorm}$).

A falling edge on pin SLP_N in Normal mode initiates a transition to Sleep mode. The LIN transmit path is immediately disabled when pin SLP_N goes LOW. In order to ensure the TJA1029 switches successfully to Sleep mode, the sleep command (pin SLP_N = LOW) must be maintained for at least $t_{gotosleep}$.

Sleep mode activation is independent of the levels on pins LIN or TXD. So the lowest possible power consumption can be guaranteed, even when there is a continuous dominant level on pins LIN and TXD.

7.2.3 Standby mode

Standby mode is activated automatically when a local or remote wake-up event occurs while the TJA1029 is in Sleep mode. In Standby mode, pin RXD is held LOW to provide an interrupt flag for the microcontroller.

7.2.4 Normal mode

In Normal mode, the TJA1029 can transmit and receive data via the LIN bus.

The receiver detects the data stream on the LIN bus input pin and transfers it via pin RXD to the microcontroller (see [Figure 6](#)): HIGH for a recessive level and LOW for a dominant level on the bus. The receiver has a supply-voltage related threshold with hysteresis and an integrated filter to suppress bus line noise.

The transmitter converts the transmit data stream from the protocol controller, detected on pin TXD, into an optimized bus signal. The optimized bus signal is shaped to minimize EME. The LIN bus output pin is pulled HIGH via an internal slave termination resistor. For a master application, connect an external resistor in series with a diode between pin V_{BAT} and pin LIN (see [Figure 6](#)).

If pin SLP_N is pulled HIGH while the TJA1029 is in Sleep or Standby mode, the LIN transceiver switches to Normal mode after $t_{gotonorm}$.

7.3 Transceiver wake-up

7.3.1 Remote wake-up via the LIN bus

A falling edge on pin LIN, followed by a LOW level maintained for $t_{wake(dom)LIN}$, followed by a rising edge on pin LIN, triggers a remote wake-up (see Figure 4). Note that the time period $t_{wake(dom)LIN}$ is measured either in Normal mode while TXD is HIGH, or in Sleep mode irrespective of the status of pin TXD.

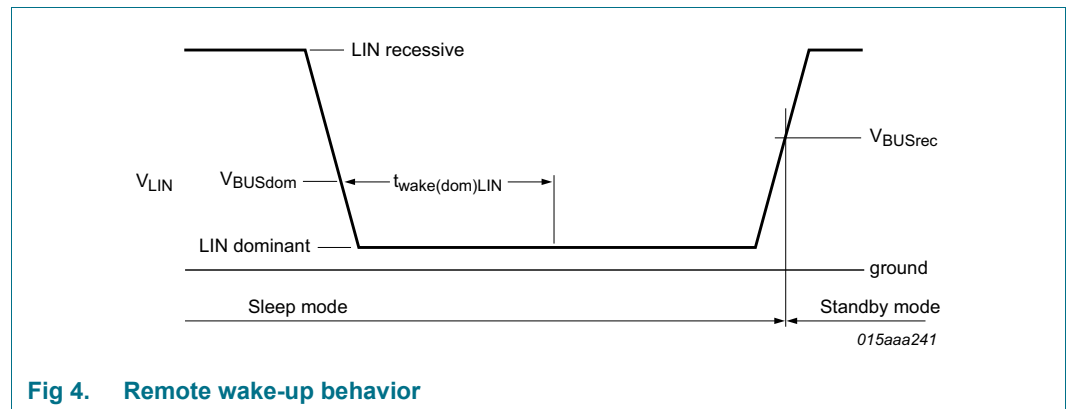

Fig 4. Remote wake-up behavior

7.3.2 Wake-up via pin SLP_N

If SLP_N is held HIGH for $t_{gotonorm}$, the TJA1029 switches from Sleep mode to Normal mode.

7.4 Operation during automotive cranking pulses

TJA1029 remains fully operational during automotive cranking pulses because the LIN transceiver is fully specified down to $V_{BAT} = 5\text{ V}$.

7.5 Operation when supply voltage is outside specified operating range

If $V_{BAT} > 18\text{ V}$ or $V_{BAT} < 5\text{ V}$, the TJA1029 may remain operational, but parameter values cannot be guaranteed to remain within the operating ranges specified in Table 7 and Table 8.

If the voltage on pin V_{BAT} drops below the LOW-level power-on reset threshold, $V_{th(POR)L}$, the TJA1029 switches to Reset mode. All output drivers are disabled and all inputs are ignored. The TJA1029 switches to Sleep mode if $V_{BAT} > V_{th(POR)H}$.

In Normal mode:

- If the input level on pin TXD is HIGH, the LIN transmitter output on pin LIN will be recessive.
- If the input level on pin LIN is recessive, the receiver output on pin RXD will be HIGH.
- If the voltage on pin V_{BAT} rises to 27 V (e.g. during an automotive jump-start), the total LIN network pull-up resistance should be greater than 680 Ω and the total LIN network capacitance should be less than 6.8 nF to ensure reliable LIN data transfer.

- If the voltage on pin V_{BAT} drops below the LOW-level V_{BAT} LOW threshold, $V_{th(VBAT)L}$, the LIN transmit path is interrupted and the LIN output remains recessive. The LIN transmit path is switched on again when V_{BAT} rises above $V_{th(VBAT)H}$ and the input to pin TXD is recessive.

7.6 TXD dominant time-out function

An initial TXD dominant check prevents the bus line being driven to a permanent dominant state (blocking all network communications) if pin TXD is forced permanently LOW by a hardware and/or software application failure. The TXD input level is checked after a transition to Normal mode. If TXD is LOW, the transmit path remains disabled and is only enabled when TXD goes HIGH.

Once the transmitter has been enabled, a TXD dominant time-out timer is started every time pin TXD goes LOW. If the LOW state on pin TXD persists for longer than the TXD dominant time-out time ($t_{to(dom)TXD}$), the transmitter is disabled, releasing the bus line to recessive state. The TXD dominant time-out timer is reset when pin TXD goes HIGH.

7.7 Fail-safe features

A pull-down to GND on pin TXD forces a predefined level on the transmit data input if the pin is disconnected.

A pull-down to GND on pin SLP_N forces the transceiver into Sleep mode if pin SLP_N is disconnected.

Pin RXD is set floating if V_{BAT} is disconnected.

The current in the transmitter output stage is limited in order to protect the transmitter against short circuits to pins V_{BAT} or GND.

A loss of power (pins V_{BAT} and GND) has no impact on the bus line or on the microcontroller. No reverse currents flow from the bus into pin LIN. The current path from V_{BAT} to LIN via the integrated LIN slave termination resistor remains. The LIN transceiver can be disconnected from the power supply without influencing the LIN bus.

The output driver on pin LIN is protected against overtemperature conditions. If the junction temperature exceeds the shutdown junction temperature, $T_{j(sd)}$, the thermal protection circuit disables the output driver. The driver is enabled again when the junction temperature falls below $T_{j(sd)}$ and pin TXD is recessive.

8. Limiting values

Table 5. Limiting values

In accordance with the Absolute Maximum Rating System (IEC 60134). All voltages are referenced to pin GND, unless otherwise specified. Positive currents flow into the IC.

| Symbol | Parameter | Conditions | Min | Max | Unit |
|--------------------|---------------------------------|--|----------|------|------|
| V _{BAT} | battery supply voltage | | -0.3 | +42 | V |
| V _{TXD} | voltage on pin TXD | | -0.3 | +7 | V |
| V _{RXD} | voltage on pin RXD | | -0.3 | +7 | V |
| V _{SLP_N} | voltage on pin SLP_N | | -0.3 | +7 | V |
| V _{LIN} | voltage on pin LIN | with respect to GND and V _{BAT} | -42 | +42 | V |
| V _{ESD} | electrostatic discharge voltage | | | | |
| | according to IEC 61000-4-2 | on pins LIN and V _{BAT} | [1] -8 | +8 | kV |
| | human body model | on pins LIN and V _{BAT} | [2] -8 | +8 | kV |
| | | on pins TXD, RXD and SLP_N | [2] -2 | +2 | kV |
| | charge device model | all pins | -750 | +750 | V |
| | machine model | all pins | [3] -200 | +200 | V |
| T _{vj} | virtual junction temperature | | [4] -40 | +150 | °C |
| T _{stg} | storage temperature | | -55 | +150 | °C |

[1] Equivalent to discharging a 150 pF capacitor through a 330 Ω resistor.

[2] Equivalent to discharging a 100 pF capacitor through a 1.5 kΩ resistor.

[3] Equivalent to discharging a 200 pF capacitor through a 10 Ω resistor and a 0.75 μH coil.

[4] Junction temperature in accordance with IEC 60747-1. An alternative definition is: $T_j = T_{amb} + P \times R_{th(j-a)}$, where $R_{th(j-a)}$ is a fixed value. The rating for T_{vj} limits the allowable combinations of power dissipation (P) and ambient temperature (T_{amb}).

9. Thermal characteristics

Table 6. Thermal characteristics

According to IEC 60747-1.

| Symbol | Parameter | Conditions | Typ | Unit |
|----------------------|---|-----------------------------|-----|------|
| R _{th(j-a)} | thermal resistance from junction to ambient | SO8 package; in free air | 145 | K/W |
| | | HVSON8 package; in free air | 50 | K/W |

10. Static characteristics

Table 7. Static characteristics

$V_{BAT} = 5\text{ V to }18\text{ V}$; $T_{vj} = -40\text{ }^{\circ}\text{C to }+150\text{ }^{\circ}\text{C}$; $R_{L(LIN-VBAT)} = 500\ \Omega$; all voltages are referenced to pin GND; positive currents flow into the IC; typical values are given at $V_{BAT} = 12\text{ V}$; unless otherwise specified.^[1]

| Symbol | Parameter | Conditions | Min | Typ | Max | Unit |
|-----------------------------|---|--|----------|-----|------|---------------|
| Supply | | | | | | |
| V_{BAT} | battery supply voltage | | 5 | - | 18 | V |
| I_{BAT} | battery supply current | Sleep mode; bus recessive; $V_{LIN} = V_{BAT}$; $V_{SLP_N} = 0\text{ V}$ | 2.5 | 7 | 10 | μA |
| | | Sleep mode; bus dominant; $V_{LIN} = 0\text{ V}$; $V_{BAT} = 12\text{ V}$; $V_{SLP_N} = 0\text{ V}$ | 150 | 400 | 1200 | μA |
| | | Standby mode; bus recessive; $V_{LIN} = V_{BAT}$; $V_{SLP_N} = 0\text{ V}$ | 2.5 | 7 | 10 | μA |
| | | Standby mode; bus dominant; $V_{LIN} = 0\text{ V}$; $V_{BAT} = 12\text{ V}$; $V_{SLP_N} = 0\text{ V}$ | [2] 100 | 300 | 1000 | μA |
| | | Normal mode; bus recessive; $V_{LIN} = V_{BAT}$; $V_{SLP_N} = 5\text{ V}$; $V_{TXD} = 5\text{ V}$ | 200 | 800 | 1600 | μA |
| | | Normal mode; bus dominant; $V_{TXD} = 0\text{ V}$; $V_{SLP_N} = 5\text{ V}$; $V_{BAT} = 12\text{ V}$ | 1 | 2 | 4 | mA |
| Undervoltage reset | | | | | | |
| $V_{th(POR)L}$ | LOW-level power-on reset threshold voltage | power-on reset | 1.6 | 3.1 | 3.9 | V |
| $V_{th(POR)H}$ | HIGH-level power-on reset threshold voltage | | 2.3 | 3.4 | 4.3 | V |
| $V_{hys(POR)}$ | power-on reset hysteresis voltage | | [2] 0.05 | 0.3 | 1 | V |
| $V_{th(VBATL)L}$ | LOW-level V_{BAT} LOW threshold voltage | | 3.9 | 4.4 | 4.7 | V |
| $V_{th(VBATL)H}$ | HIGH-level V_{BAT} LOW threshold voltage | | 4.2 | 4.7 | 4.9 | V |
| $V_{hys(VBATL)}$ | V_{BAT} LOW hysteresis voltage | | [2] 0.15 | 0.3 | 0.6 | V |
| Pins TXD and SLP_N | | | | | | |
| V_{IH} | HIGH-level input voltage | | 2 | - | 7 | V |
| V_{IL} | LOW-level input voltage | | -0.3 | - | +0.8 | V |
| V_{hys} | hysteresis voltage | | [2] 50 | 200 | 400 | mV |
| R_{pd} | pull-down resistance | on TXD | 50 | 125 | 325 | k Ω |
| | | on SLP_N | 100 | 250 | 650 | k Ω |
| Pin RXD (open-drain) | | | | | | |
| I_{OL} | LOW-level output current | $V_{RXD} = 0.4\text{ V}$ | 2 | - | - | mA |
| I_{LH} | HIGH-level leakage current | | [2] -5 | - | +5 | μA |

Table 7. Static characteristics ...continued

$V_{BAT} = 5\text{ V to }18\text{ V}$; $T_{vj} = -40\text{ }^{\circ}\text{C to }+150\text{ }^{\circ}\text{C}$; $R_{L(LIN-VBAT)} = 500\ \Omega$; all voltages are referenced to pin GND; positive currents flow into the IC; typical values are given at $V_{BAT} = 12\text{ V}$; unless otherwise specified.^[1]

| Symbol | Parameter | Conditions | Min | Typ | Max | Unit |
|-------------------------|--|---|----------------|--------------|----------------|--------------------|
| Pin LIN | | | | | | |
| I_{BUS_LIM} | current limitation for driver dominant state | $V_{BAT} = 18\text{ V}$; $V_{LIN} = 18\text{ V}$; $V_{TXD} = 0\text{ V}$ | 40 | - | 100 | mA |
| $I_{BUS_PAS_dom}$ | receiver dominant input leakage current including pull-up resistor | $V_{BAT} = 12\text{ V}$; $V_{LIN} = 0\text{ V}$; $V_{TXD} = 5\text{ V}$ | [2] -600 | - | - | μA |
| $I_{BUS_PAS_rec}$ | receiver recessive input leakage current | $V_{BAT} = 5\text{ V}$; $V_{LIN} = 18\text{ V}$; $V_{TXD} = 5\text{ V}$ | [2] - | 0 | 1 | μA |
| $I_{BUS_NO_GND}$ | loss-of-ground bus current | $V_{BAT} = 18\text{ V}$; $V_{LIN} = 0\text{ V}$ | [2] -750 | - | +10 | μA |
| $I_{BUS_NO_BAT}$ | loss-of-battery bus current | $V_{BAT} = 0\text{ V}$; $V_{LIN} = 18\text{ V}$ | [2] - | - | 1 | μA |
| V_{BUSdom} | receiver dominant state | | - | - | $0.4V_{BAT}$ | V |
| V_{BUSrec} | receiver recessive state | | $0.6V_{BAT}$ | - | - | V |
| V_{BUS_CNT} | receiver center voltage | $V_{BUS_CNT} =$ $(V_{BUSdom} + V_{BUSrec}) / 2$ | $0.475V_{BAT}$ | $0.5V_{BAT}$ | $0.525V_{BAT}$ | V |
| V_{HYS} | receiver hysteresis voltage | $V_{HYS} = V_{BUSrec} - V_{BUSdom}$ | - | - | $0.175V_{BAT}$ | V |
| $V_{SerDiode}$ | voltage drop at the serial diode | in pull-up path with R_{slave} ; $I_{SerDiode} = 0.9\text{ mA}$ | [2] 0.4 | - | 1.0 | V |
| $V_{O(dom)}$ | dominant output voltage | Normal mode; $V_{TXD} = 0\text{ V}$; $V_{BAT} = 7.0\text{ V}$ | [2] - | - | 1.4 | V |
| | | Normal mode; $V_{TXD} = 0\text{ V}$; $V_{BAT} = 18\text{ V}$ | [2] - | - | 2.0 | V |
| R_{slave} | slave resistance | | 20 | 30 | 60 | k Ω |
| C_{LIN} | capacitance on pin LIN | with respect to GND | [2] - | - | 20 | pF |
| Thermal shutdown | | | | | | |
| $T_{j(sd)}$ | shutdown junction temperature | | [2] 150 | - | 200 | $^{\circ}\text{C}$ |

[1] All parameters are guaranteed over the virtual junction temperature range by design. Factory testing uses correlated test conditions to cover the specified temperature and power supply voltage range.

[2] Not tested in production; guaranteed by design.

11. Dynamic characteristics

Table 8. Dynamic characteristics

$V_{BAT} = 5\text{ V to }18\text{ V}$; $T_{vj} = -40\text{ }^{\circ}\text{C to }+150\text{ }^{\circ}\text{C}$; $R_{L(LIN-VBAT)} = 500\ \Omega$; all voltages are referenced to pin GND; positive currents flow into the IC; typical values are given at $V_{BAT} = 12\text{ V}$, unless otherwise specified.^[1]

| Symbol | Parameter | Conditions | Min | Typ | Max | Unit | |
|-------------------------------|-------------------------------------|--|-----------|-------|-----|-------|---------------|
| Duty cycles | | | | | | | |
| $\delta 1$ | duty cycle 1 | $V_{th(rec)(max)} = 0.744 \times V_{BAT}$; $V_{th(dom)(max)} = 0.581 \times V_{BAT}$; $t_{bit} = 50\ \mu\text{s}$; $V_{BAT} = 7\text{ V to }18\text{ V}$ | [2][4][5] | 0.396 | - | - | |
| | | $V_{th(rec)(max)} = 0.768 \times V_{BAT}$; $V_{th(dom)(max)} = 0.6 \times V_{BAT}$; $t_{bit} = 50\ \mu\text{s}$; $V_{BAT} = 5\text{ V to }7\text{ V}$ | [2][4][5] | 0.396 | - | - | |
| $\delta 2$ | duty cycle 2 | $V_{th(rec)(min)} = 0.422 \times V_{BAT}$; $V_{th(dom)(min)} = 0.284 \times V_{BAT}$; $t_{bit} = 50\ \mu\text{s}$; $V_{BAT} = 7.6\text{ V to }18\text{ V}$ | [3][4][5] | - | - | 0.581 | |
| | | $V_{th(rec)(min)} = 0.405 \times V_{BAT}$; $V_{th(dom)(min)} = 0.271 \times V_{BAT}$; $t_{bit} = 50\ \mu\text{s}$; $V_{BAT} = 5.6\text{ V to }7.6\text{ V}$ | [3][4][5] | - | - | 0.581 | |
| $\delta 3$ | duty cycle 3 | $V_{th(rec)(max)} = 0.778 \times V_{BAT}$; $V_{th(dom)(max)} = 0.616 \times V_{BAT}$; $t_{bit} = 96\ \mu\text{s}$; $V_{BAT} = 7\text{ V to }18\text{ V}$ | [2][4][5] | 0.417 | - | - | |
| | | $V_{th(rec)(max)} = 0.805 \times V_{BAT}$; $V_{th(dom)(max)} = 0.637 \times V_{BAT}$; $t_{bit} = 96\ \mu\text{s}$; $V_{BAT} = 5\text{ V to }7\text{ V}$ | [2][4][5] | 0.417 | - | - | |
| $\delta 4$ | duty cycle 4 | $V_{th(rec)(min)} = 0.389 \times V_{BAT}$; $V_{th(dom)(min)} = 0.251 \times V_{BAT}$; $t_{bit} = 96\ \mu\text{s}$; $V_{BAT} = 7.6\text{ V to }18\text{ V}$ | [3][4][5] | - | - | 0.590 | |
| | | $V_{th(rec)(min)} = 0.372 \times V_{BAT}$; $V_{th(dom)(min)} = 0.238 \times V_{BAT}$; $t_{bit} = 96\ \mu\text{s}$; $V_{BAT} = 5.6\text{ V to }7.6\text{ V}$ | [3][4][5] | - | - | 0.590 | |
| Timing characteristics | | | | | | | |
| t_{rx_pd} | receiver propagation delay | rising and falling; $C_{RXD} = 20\text{ pF}$; $R_{RXD} = 2.4\text{ k}\Omega$ | [5] | - | - | 6 | μs |
| t_{rx_sym} | receiver propagation delay symmetry | $C_{RXD} = 20\text{ pF}$; $R_{RXD} = 2.4\text{ k}\Omega$; rising edge with respect to falling edge | [5] | -2 | - | +2 | μs |
| $t_{wake(dom)LIN}$ | LIN dominant wake-up time | Sleep mode | | 30 | 80 | 150 | μs |
| $t_{gotonorm}$ | go to normal time | time period for mode change from Sleep or Standby mode to Normal mode | | 2 | 6 | 10 | μs |
| $t_{init(norm)}$ | normal mode initialization time | | | 7 | - | 20 | μs |
| $t_{gotosleep}$ | go to sleep time | time period for mode change from Normal to Sleep mode | | 2 | 6 | 10 | μs |
| $t_{to(dom)TXD}$ | TXD dominant time-out time | timer started at falling edge on TXD | | 6 | 12 | 50 | ms |

[1] All parameters are guaranteed over the virtual junction temperature range by design. Factory testing uses correlated test conditions to cover the specified temperature and power supply voltage ranges.

[2] $\delta 1, \delta 3 = \frac{t_{bus(rec)(min)}}{2 \times t_{bit}}$. Variable $t_{bus(rec)(min)}$ is illustrated in the LIN timing diagram in [Figure 5](#).

[3] $\delta 2, \delta 4 = \frac{t_{bus(rec)(max)}}{2 \times t_{bit}}$. Variable $t_{bus(rec)(max)}$ is illustrated in the LIN timing diagram in [Figure 5](#).

[4] Bus load conditions: $C_{BUS} = 1 \text{ nF}$ and $R_{BUS} = 1 \text{ k}\Omega$; $C_{BUS} = 6.8 \text{ nF}$ and $R_{BUS} = 660 \text{ }\Omega$; $C_{BUS} = 10 \text{ nF}$ and $R_{BUS} = 500 \text{ }\Omega$.

[5] See timing diagram in [Figure 5](#).

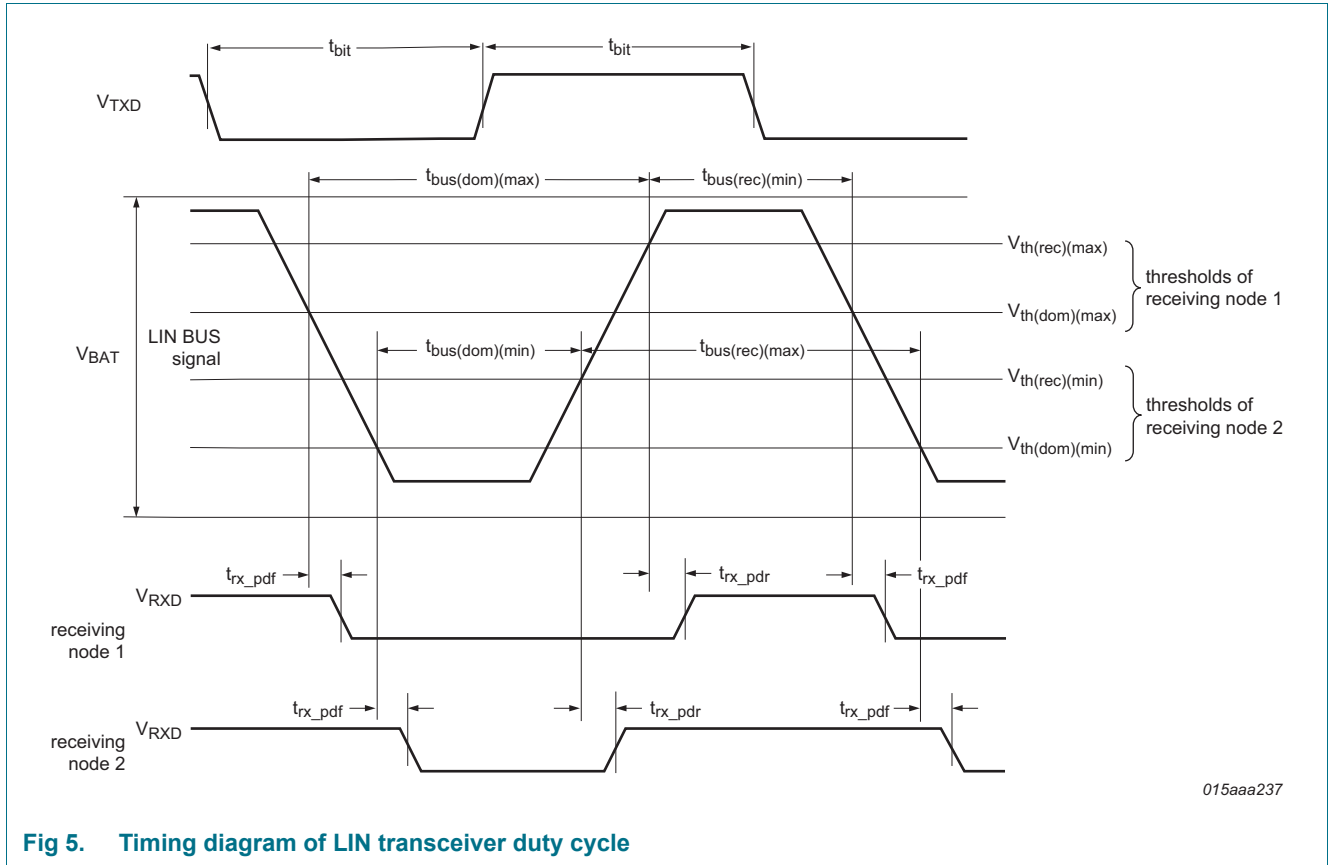
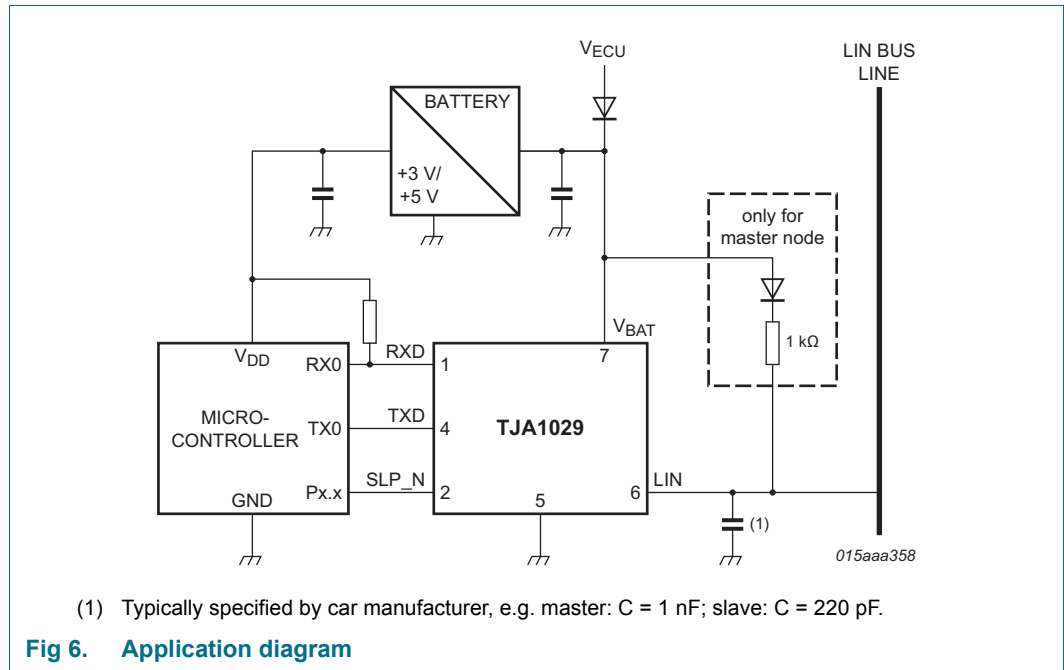

Fig 5. Timing diagram of LIN transceiver duty cycle

12. Application information

12.1 Application diagram



12.2 ESD robustness according to LIN EMC test specification

ESD robustness (IEC 61000-4-2) has been tested by an external test house according to the LIN EMC test specification (part of Conformance Test Specification Package for LIN 2.1, October 10th, 2008). The test report is available on request.

Table 9. ESD robustness (IEC 61000-4-2) according to LIN EMC test specification

| Pin | Test configuration | Value | Unit |
|------------------|--|-------|------|
| LIN | no capacitor connected to LIN pin | ±12 | kV |
| | 220 pF capacitor connected to LIN pin | ±12 | kV |
| V _{BAT} | 100 nF capacitor connected to V _{BAT} pin | > 14 | kV |

12.3 Hardware requirements for LIN interfaces in automotive applications

The TJA1029 satisfies the "Hardware Requirements for LIN, CAN and FlexRay Interfaces in Automotive Applications", Version 1.3, May 2012.

13. Test information

13.1 Quality information

This product has been qualified in accordance with the Automotive Electronics Council (AEC) standard Q100 Rev-G - *Failure mechanism based stress test qualification for integrated circuits*, and is suitable for use in automotive applications.

14. Package outline

SO8: plastic small outline package; 8 leads; body width 3.9 mm

SOT96-1

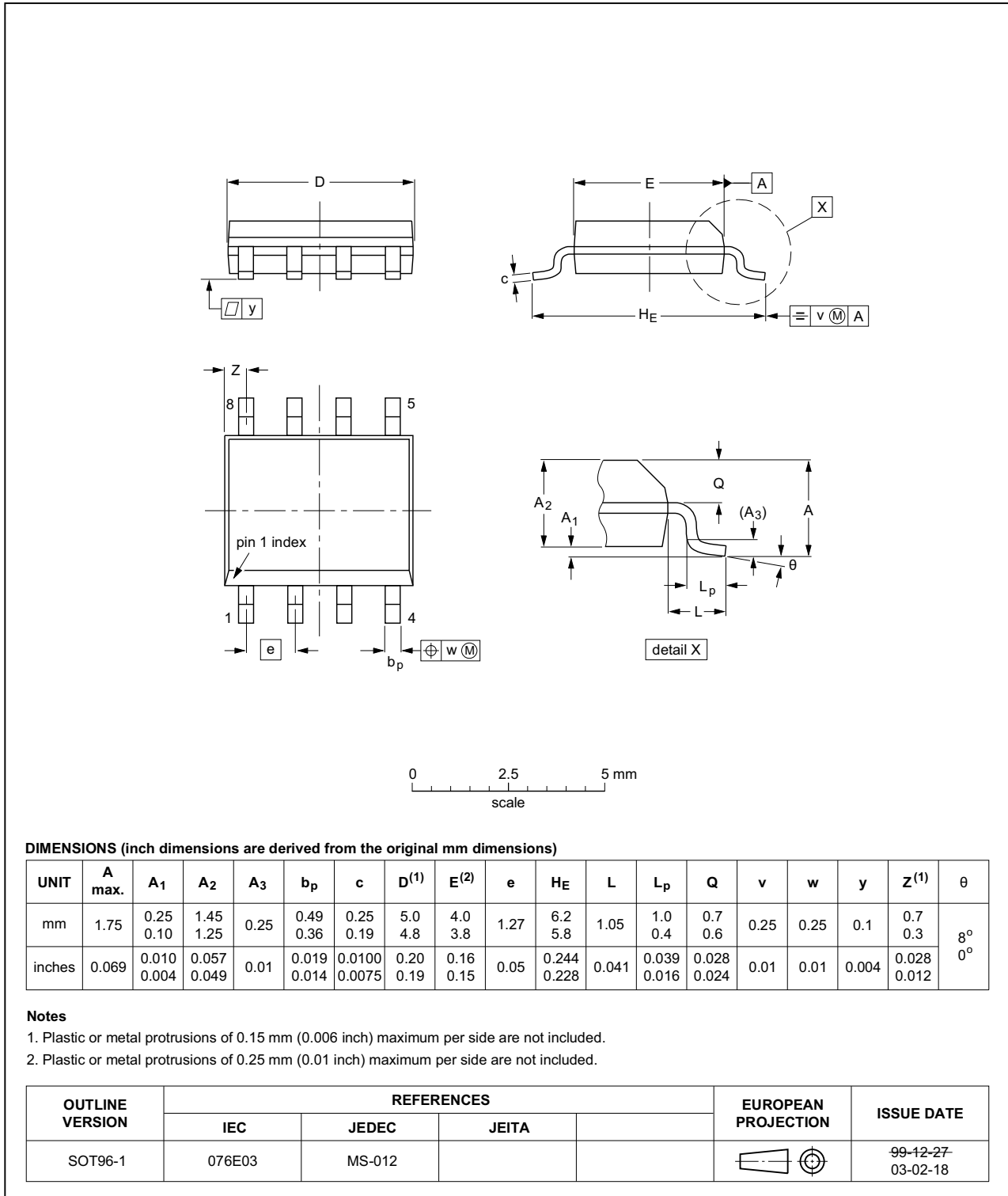

Fig 7. Package outline SOT96-1 (SO8)

**HVSON8: plastic thermal enhanced very thin small outline package; no leads;
8 terminals; body 3 x 3 x 0.85 mm**

SOT782-1

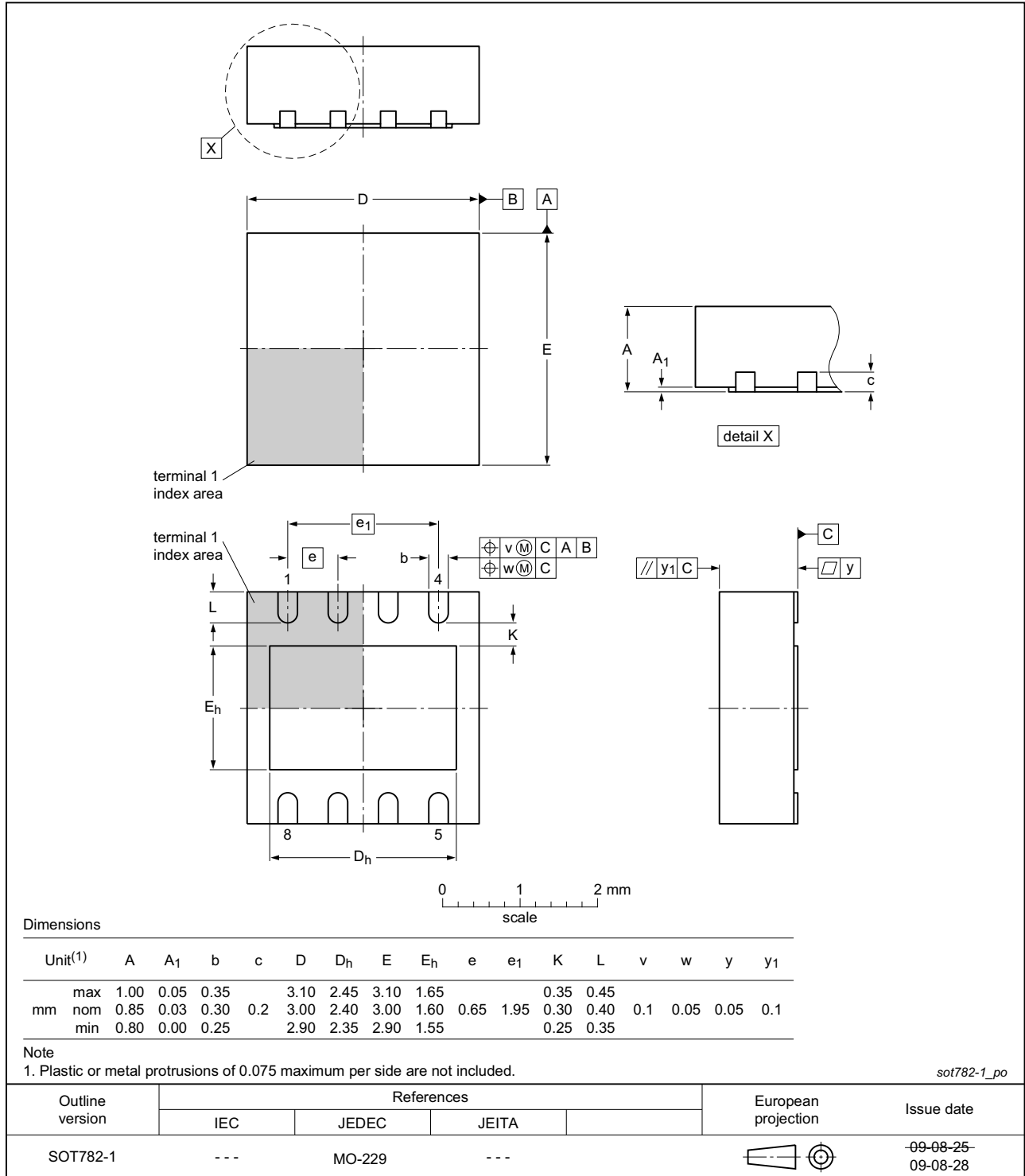

Fig 8. Package outline SOT782-1 (HVSON8)

15. Handling information

All input and output pins are protected against ElectroStatic Discharge (ESD) under normal handling. When handling ensure that the appropriate precautions are taken as described in *JESD625-A* or equivalent standards.

16. Soldering of SMD packages

This text provides a very brief insight into a complex technology. A more in-depth account of soldering ICs can be found in Application Note *AN10365 "Surface mount reflow soldering description"*.

16.1 Introduction to soldering

Soldering is one of the most common methods through which packages are attached to Printed Circuit Boards (PCBs), to form electrical circuits. The soldered joint provides both the mechanical and the electrical connection. There is no single soldering method that is ideal for all IC packages. Wave soldering is often preferred when through-hole and Surface Mount Devices (SMDs) are mixed on one printed wiring board; however, it is not suitable for fine pitch SMDs. Reflow soldering is ideal for the small pitches and high densities that come with increased miniaturization.

16.2 Wave and reflow soldering

Wave soldering is a joining technology in which the joints are made by solder coming from a standing wave of liquid solder. The wave soldering process is suitable for the following:

- Through-hole components
- Leaded or leadless SMDs, which are glued to the surface of the printed circuit board

Not all SMDs can be wave soldered. Packages with solder balls, and some leadless packages which have solder lands underneath the body, cannot be wave soldered. Also, leaded SMDs with leads having a pitch smaller than ~0.6 mm cannot be wave soldered, due to an increased probability of bridging.

The reflow soldering process involves applying solder paste to a board, followed by component placement and exposure to a temperature profile. Leaded packages, packages with solder balls, and leadless packages are all reflow solderable.

Key characteristics in both wave and reflow soldering are:

- Board specifications, including the board finish, solder masks and vias
- Package footprints, including solder thieves and orientation
- The moisture sensitivity level of the packages
- Package placement
- Inspection and repair
- Lead-free soldering versus SnPb soldering

16.3 Wave soldering

Key characteristics in wave soldering are:

- Process issues, such as application of adhesive and flux, clinching of leads, board transport, the solder wave parameters, and the time during which components are exposed to the wave
- Solder bath specifications, including temperature and impurities

16.4 Reflow soldering

Key characteristics in reflow soldering are:

- Lead-free versus SnPb soldering; note that a lead-free reflow process usually leads to higher minimum peak temperatures (see [Figure 9](#)) than a SnPb process, thus reducing the process window
- Solder paste printing issues including smearing, release, and adjusting the process window for a mix of large and small components on one board
- Reflow temperature profile; this profile includes preheat, reflow (in which the board is heated to the peak temperature) and cooling down. It is imperative that the peak temperature is high enough for the solder to make reliable solder joints (a solder paste characteristic). In addition, the peak temperature must be low enough that the packages and/or boards are not damaged. The peak temperature of the package depends on package thickness and volume and is classified in accordance with [Table 10](#) and [11](#)

Table 10. SnPb eutectic process (from J-STD-020D)

| Package thickness (mm) | Package reflow temperature (°C) | |
|------------------------|---------------------------------|-------|
| | Volume (mm ³) | |
| | < 350 | ≥ 350 |
| < 2.5 | 235 | 220 |
| ≥ 2.5 | 220 | 220 |

Table 11. Lead-free process (from J-STD-020D)

| Package thickness (mm) | Package reflow temperature (°C) | | |
|------------------------|---------------------------------|-------------|--------|
| | Volume (mm ³) | | |
| | < 350 | 350 to 2000 | > 2000 |
| < 1.6 | 260 | 260 | 260 |
| 1.6 to 2.5 | 260 | 250 | 245 |
| > 2.5 | 250 | 245 | 245 |

Moisture sensitivity precautions, as indicated on the packing, must be respected at all times.

Studies have shown that small packages reach higher temperatures during reflow soldering, see [Figure 9](#).

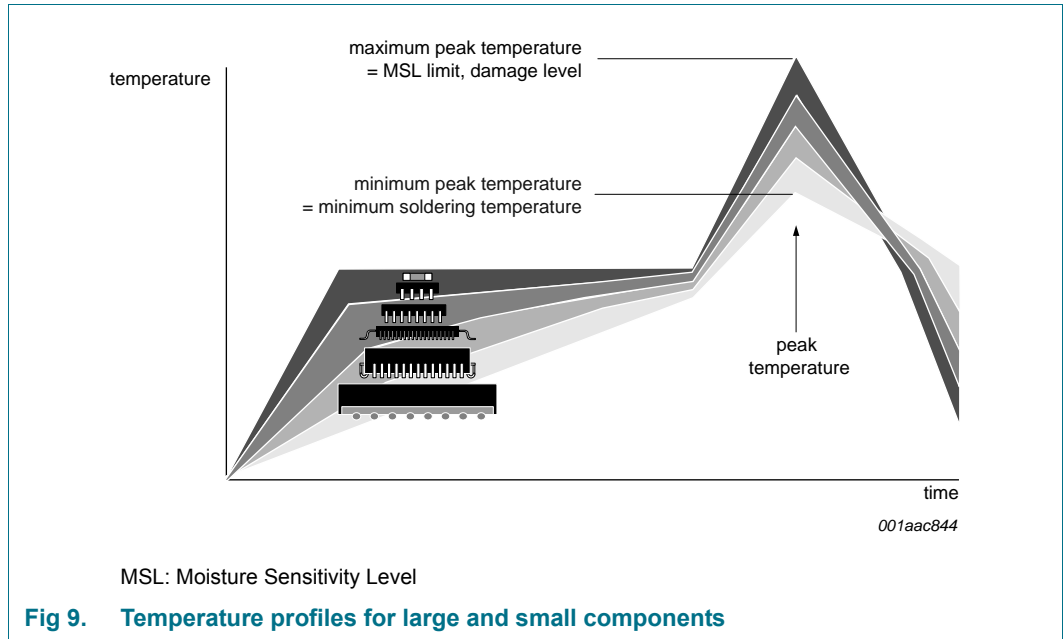

For further information on temperature profiles, refer to Application Note AN10365 “Surface mount reflow soldering description”.

17. Soldering of HVSON packages

[Section 16](#) contains a brief introduction to the techniques most commonly used to solder Surface Mounted Devices (SMD). A more detailed discussion on soldering HVSON leadless package ICs can be found in the following application notes:

- AN10365 “Surface mount reflow soldering description”
- AN10366 “HVQFN application information”

18. Revision history

Table 12. Revision history

| Document ID | Release date | Data sheet status | Change notice | Supersedes |
|----------------|---|--------------------|---------------|-------------|
| TJA1029 v.3 | 20181218 | Product data sheet | - | TJA1029 v.2 |
| Modifications: | <ul style="list-style-type: none"> • ISO 17987-4:2016 (12 V) compliant • Section 2.1: pin compatible with TJA1020, TJA1021, TJA1022 and MC33662; pin- and footprint-compatible TJA1027 • Figure 6, Figure note 1 revised | | | |
| TJA1029 v.2 | 20130424 | Product data sheet | - | TJA1029 v.1 |
| TJA1029 v.1 | 20130108 | Product data sheet | - | - |

19. Legal information

19.1 Data sheet status

| Document status ^{[1][2]} | Product status ^[3] | Definition |
|-----------------------------------|-------------------------------|---|
| Objective [short] data sheet | Development | This document contains data from the objective specification for product development. |
| Preliminary [short] data sheet | Qualification | This document contains data from the preliminary specification. |
| Product [short] data sheet | Production | This document contains the product specification. |

[1] Please consult the most recently issued document before initiating or completing a design.

[2] The term 'short data sheet' is explained in section "Definitions".

[3] The product status of device(s) described in this document may have changed since this document was published and may differ in case of multiple devices. The latest product status information is available on the Internet at URL <http://www.nxp.com>.

19.2 Definitions

Draft — The document is a draft version only. The content is still under internal review and subject to formal approval, which may result in modifications or additions. NXP Semiconductors does not give any representations or warranties as to the accuracy or completeness of information included herein and shall have no liability for the consequences of use of such information.

Short data sheet — A short data sheet is an extract from a full data sheet with the same product type number(s) and title. A short data sheet is intended for quick reference only and should not be relied upon to contain detailed and full information. For detailed and full information see the relevant full data sheet, which is available on request via the local NXP Semiconductors sales office. In case of any inconsistency or conflict with the short data sheet, the full data sheet shall prevail.

Product specification — The information and data provided in a Product data sheet shall define the specification of the product as agreed between NXP Semiconductors and its customer, unless NXP Semiconductors and customer have explicitly agreed otherwise in writing. In no event however, shall an agreement be valid in which the NXP Semiconductors product is deemed to offer functions and qualities beyond those described in the Product data sheet.

19.3 Disclaimers

Limited warranty and liability — Information in this document is believed to be accurate and reliable. However, NXP Semiconductors does not give any representations or warranties, expressed or implied, as to the accuracy or completeness of such information and shall have no liability for the consequences of use of such information. NXP Semiconductors takes no responsibility for the content in this document if provided by an information source outside of NXP Semiconductors.

In no event shall NXP Semiconductors be liable for any indirect, incidental, punitive, special or consequential damages (including - without limitation - lost profits, lost savings, business interruption, costs related to the removal or replacement of any products or rework charges) whether or not such damages are based on tort (including negligence), warranty, breach of contract or any other legal theory.

Notwithstanding any damages that customer might incur for any reason whatsoever, NXP Semiconductors' aggregate and cumulative liability towards customer for the products described herein shall be limited in accordance with the *Terms and conditions of commercial sale* of NXP Semiconductors.

Right to make changes — NXP Semiconductors reserves the right to make changes to information published in this document, including without limitation specifications and product descriptions, at any time and without notice. This document supersedes and replaces all information supplied prior to the publication hereof.

Suitability for use in automotive applications — This NXP Semiconductors product has been qualified for use in automotive applications. Unless otherwise agreed in writing, the product is not designed, authorized or warranted to be suitable for use in life support, life-critical or safety-critical systems or equipment, nor in applications where failure or malfunction of an NXP Semiconductors product can reasonably be expected to result in personal injury, death or severe property or environmental damage. NXP Semiconductors and its suppliers accept no liability for inclusion and/or use of NXP Semiconductors products in such equipment or applications and therefore such inclusion and/or use is at the customer's own risk.

Applications — Applications that are described herein for any of these products are for illustrative purposes only. NXP Semiconductors makes no representation or warranty that such applications will be suitable for the specified use without further testing or modification.

Customers are responsible for the design and operation of their applications and products using NXP Semiconductors products, and NXP Semiconductors accepts no liability for any assistance with applications or customer product design. It is customer's sole responsibility to determine whether the NXP Semiconductors product is suitable and fit for the customer's applications and products planned, as well as for the planned application and use of customer's third party customer(s). Customers should provide appropriate design and operating safeguards to minimize the risks associated with their applications and products.

NXP Semiconductors does not accept any liability related to any default, damage, costs or problem which is based on any weakness or default in the customer's applications or products, or the application or use by customer's third party customer(s). Customer is responsible for doing all necessary testing for the customer's applications and products using NXP Semiconductors products in order to avoid a default of the applications and the products or of the application or use by customer's third party customer(s). NXP does not accept any liability in this respect.

Limiting values — Stress above one or more limiting values (as defined in the Absolute Maximum Ratings System of IEC 60134) will cause permanent damage to the device. Limiting values are stress ratings only and (proper) operation of the device at these or any other conditions above those given in the Recommended operating conditions section (if present) or the Characteristics sections of this document is not warranted. Constant or repeated exposure to limiting values will permanently and irreversibly affect the quality and reliability of the device.

Terms and conditions of commercial sale — NXP Semiconductors products are sold subject to the general terms and conditions of commercial sale, as published at <http://www.nxp.com/profile/terms>, unless otherwise agreed in a valid written individual agreement. In case an individual agreement is concluded only the terms and conditions of the respective agreement shall apply. NXP Semiconductors hereby expressly objects to applying the customer's general terms and conditions with regard to the purchase of NXP Semiconductors products by customer.

No offer to sell or license — Nothing in this document may be interpreted or construed as an offer to sell products that is open for acceptance or the grant, conveyance or implication of any license under any copyrights, patents or other industrial or intellectual property rights.

Export control — This document as well as the item(s) described herein may be subject to export control regulations. Export might require a prior authorization from competent authorities.

Translations — A non-English (translated) version of a document is for reference only. The English version shall prevail in case of any discrepancy between the translated and English versions.

Quick reference data — The Quick reference data is an extract of the product data given in the Limiting values and Characteristics sections of this document, and as such is not complete, exhaustive or legally binding.

19.4 Trademarks

Notice: All referenced brands, product names, service names and trademarks are the property of their respective owners.

20. Contact information

For more information, please visit: <http://www.nxp.com>

For sales office addresses, please send an email to: salesaddresses@nxp.com

21. Contents

| | | | | | |
|-----------|--|-----------|-----------|--|-----------|
| 1 | General description | 1 | 17 | Soldering of HVSON packages | 20 |
| 2 | Features and benefits | 1 | 18 | Revision history | 21 |
| 2.1 | General | 1 | 19 | Legal information | 22 |
| 2.2 | Protection | 2 | 19.1 | Data sheet status | 22 |
| 3 | Quick reference data | 2 | 19.2 | Definitions | 22 |
| 4 | Ordering information | 2 | 19.3 | Disclaimers | 22 |
| 5 | Block diagram | 3 | 19.4 | Trademarks | 23 |
| 6 | Pinning information | 4 | 20 | Contact information | 23 |
| 6.1 | Pinning | 4 | 21 | Contents | 24 |
| 6.2 | Pin description | 4 | | | |
| 7 | Functional description | 5 | | | |
| 7.1 | LIN 2.x/ISO 17987-4:2016 (12 V)/SAE J2602 compliant | 5 | | | |
| 7.2 | Operating modes | 5 | | | |
| 7.2.1 | Reset mode | 7 | | | |
| 7.2.2 | Sleep mode | 7 | | | |
| 7.2.3 | Standby mode | 7 | | | |
| 7.2.4 | Normal mode | 7 | | | |
| 7.3 | Transceiver wake-up | 8 | | | |
| 7.3.1 | Remote wake-up via the LIN bus | 8 | | | |
| 7.3.2 | Wake-up via pin SLP_N | 8 | | | |
| 7.4 | Operation during automotive cranking pulses | 8 | | | |
| 7.5 | Operation when supply voltage is outside specified operating range | 8 | | | |
| 7.6 | TXD dominant time-out function | 9 | | | |
| 7.7 | Fail-safe features | 9 | | | |
| 8 | Limiting values | 10 | | | |
| 9 | Thermal characteristics | 10 | | | |
| 10 | Static characteristics | 11 | | | |
| 11 | Dynamic characteristics | 13 | | | |
| 12 | Application information | 15 | | | |
| 12.1 | Application diagram | 15 | | | |
| 12.2 | ESD robustness according to LIN EMC test specification | 15 | | | |
| 12.3 | Hardware requirements for LIN interfaces in automotive applications | 15 | | | |
| 13 | Test information | 15 | | | |
| 13.1 | Quality information | 15 | | | |
| 14 | Package outline | 16 | | | |
| 15 | Handling information | 18 | | | |
| 16 | Soldering of SMD packages | 18 | | | |
| 16.1 | Introduction to soldering | 18 | | | |
| 16.2 | Wave and reflow soldering | 18 | | | |
| 16.3 | Wave soldering | 18 | | | |
| 16.4 | Reflow soldering | 19 | | | |

Please be aware that important notices concerning this document and the product(s) described herein, have been included in section 'Legal information'.

© NXP B.V. 2018.

All rights reserved.

For more information, please visit: <http://www.nxp.com>

For sales office addresses, please send an email to: salesaddresses@nxp.com

Date of release: 18 December 2018

Document identifier: TJA1029